

G1- Flagship Version C

End INSPIRE Dexterous Hand

Disassembly and Assembly Guide Manual V1.0

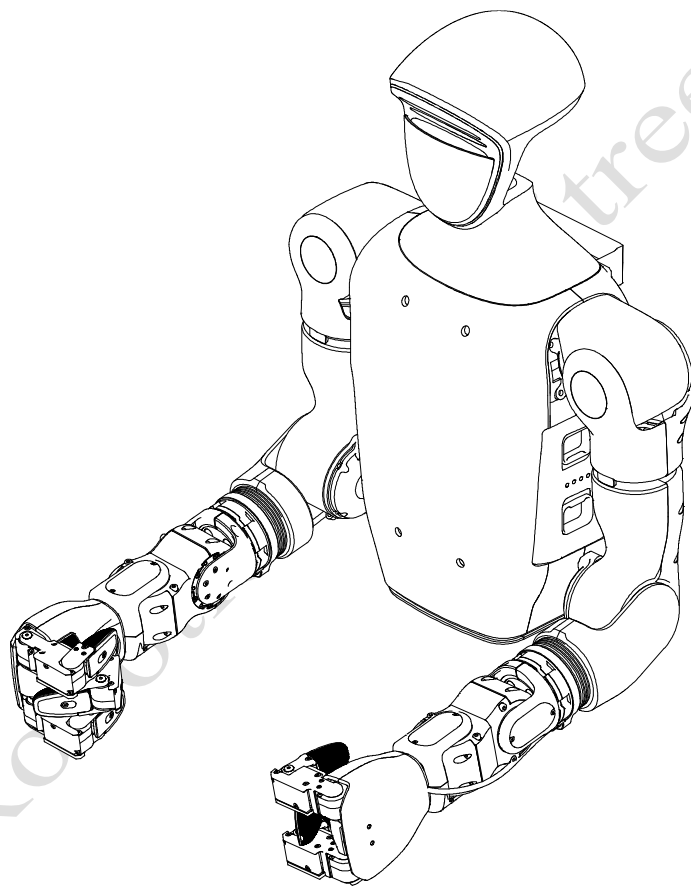

Unitree

After installing the dexterous hand, avoid movements such as squatting and lying down to prevent damage.

This product is a civilian robot. We kindly request that all users refrain from making any dangerous modifications or using the robot in a hazardous manner.

Please visit Unitree Robotics Website for more related terms and policies, and comply with local laws and regulations.

Catalogue

Disassembly Instructions	2
Step1: Remove the Cover Plate.....	2
Step2: Remove the INSPIRE Dexterous Hand	2
Step3: Remove the cable clips	3
Step4: Disconnect the Connector.....	3
Installation Instructions	4
Step1: Install the Fixed Base, Signal Cable Circuit Board, and Fixed Cover.....	4
Step2: Install the INSPIRE Dexterous Hand.....	4
Step3: Install the cover plate	5
Step4: Install Cable Clamps	6
Step5: Connect the Connector.....	6
Step6: Complete the installation	7

Disassembly Instructions

Step1: Remove the Cover Plate

Remove two M2 screws from the hand section, then extract the cover plate as shown in the figure below.

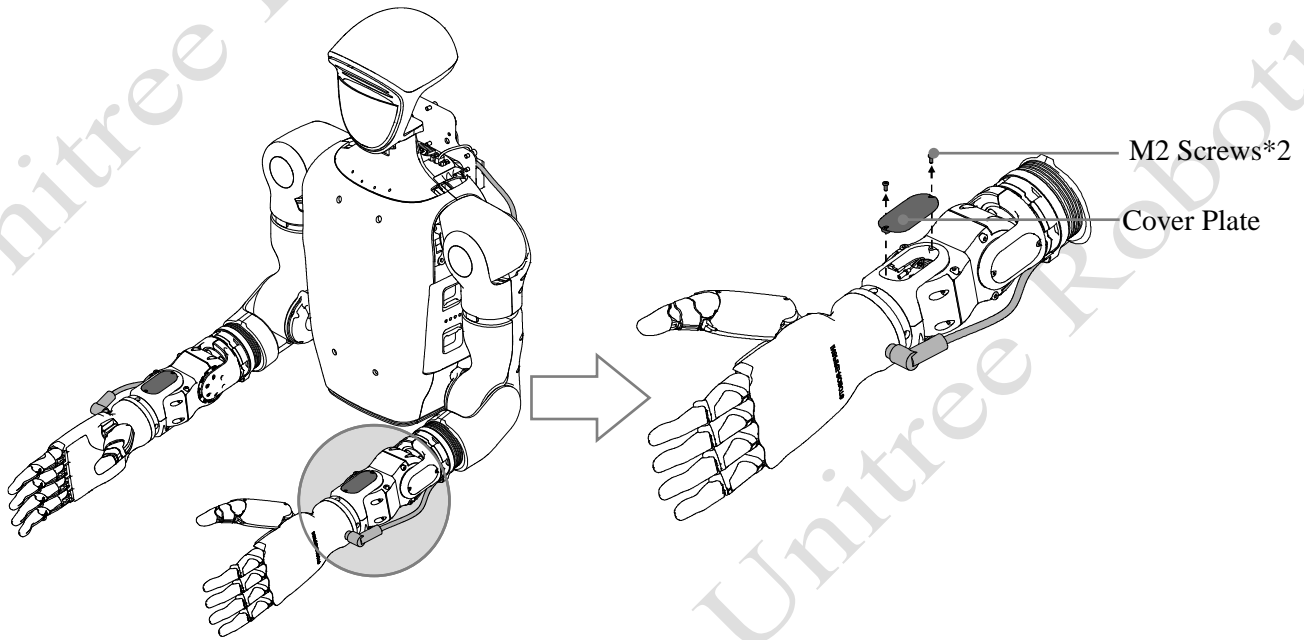

Step2: Remove the INSPIRE Dexterous Hand

Remove two M3 screws, take out the clamp (mind the cables), and then remove the INSPIRE dexterous hand, as shown below.

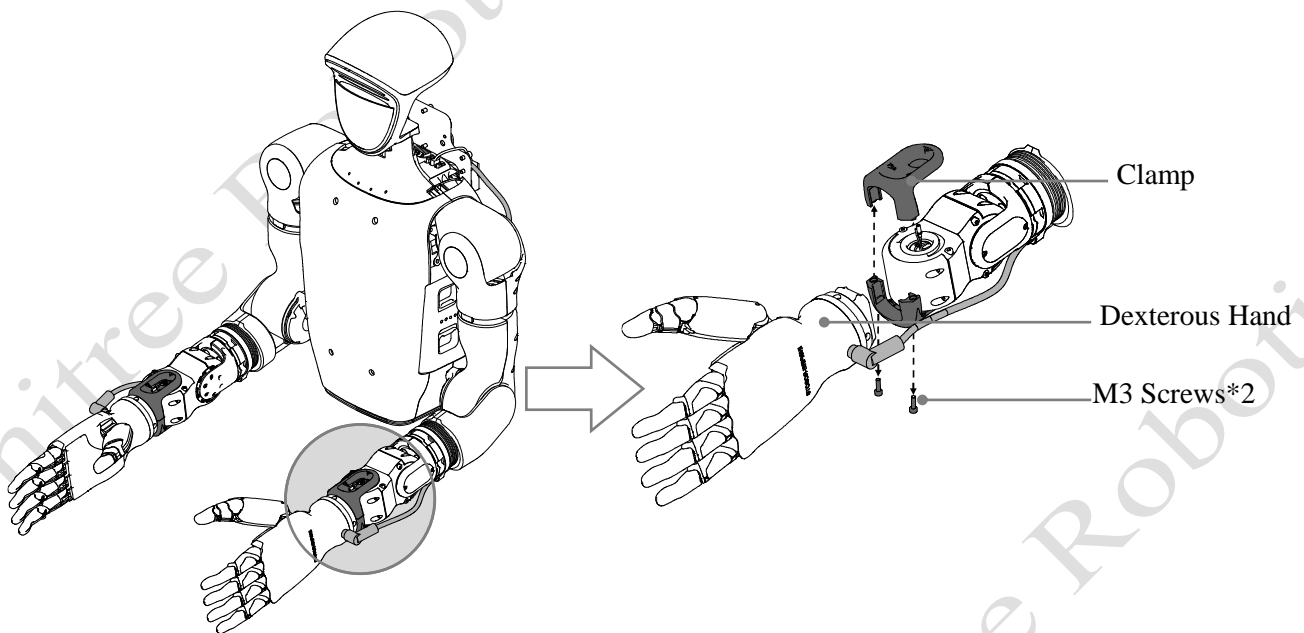

Step3: Remove the cable clips

Remove one M4 screw and take out Cable Clamp 1. Remove two M4 screws and take out Cable Clamp 2. Remove two M4 screws and take out Cable Clamp 3. Remove two M4 screws and take out Cable Clamp 4, as shown below.

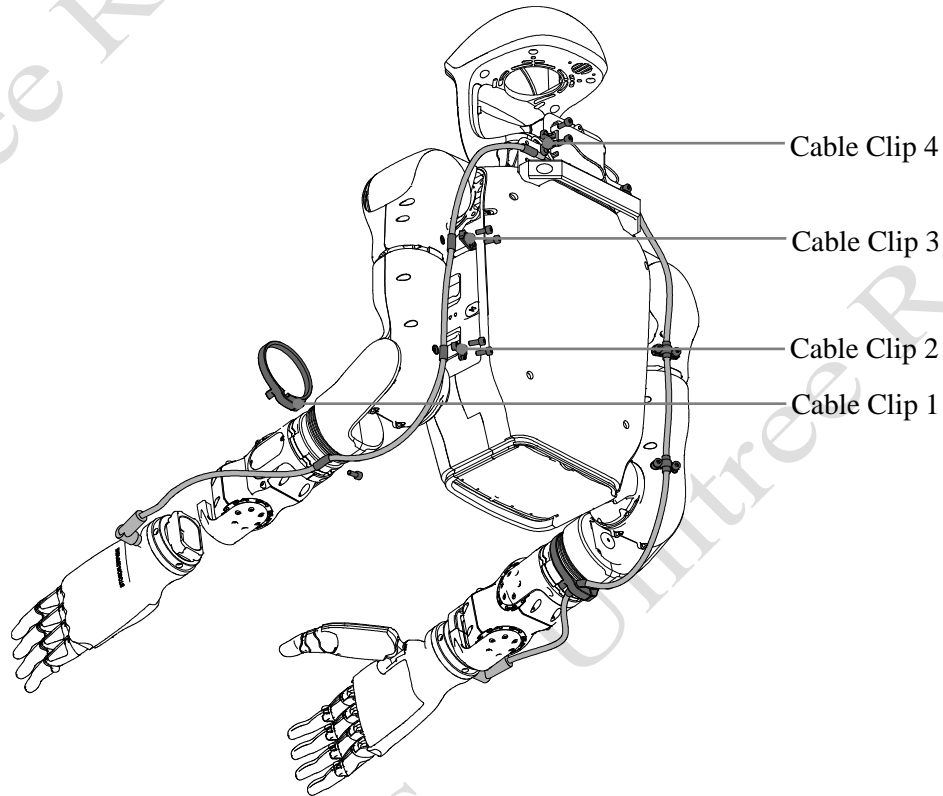

Step4: Disconnect the Connector

Unplug the connector, as shown below.

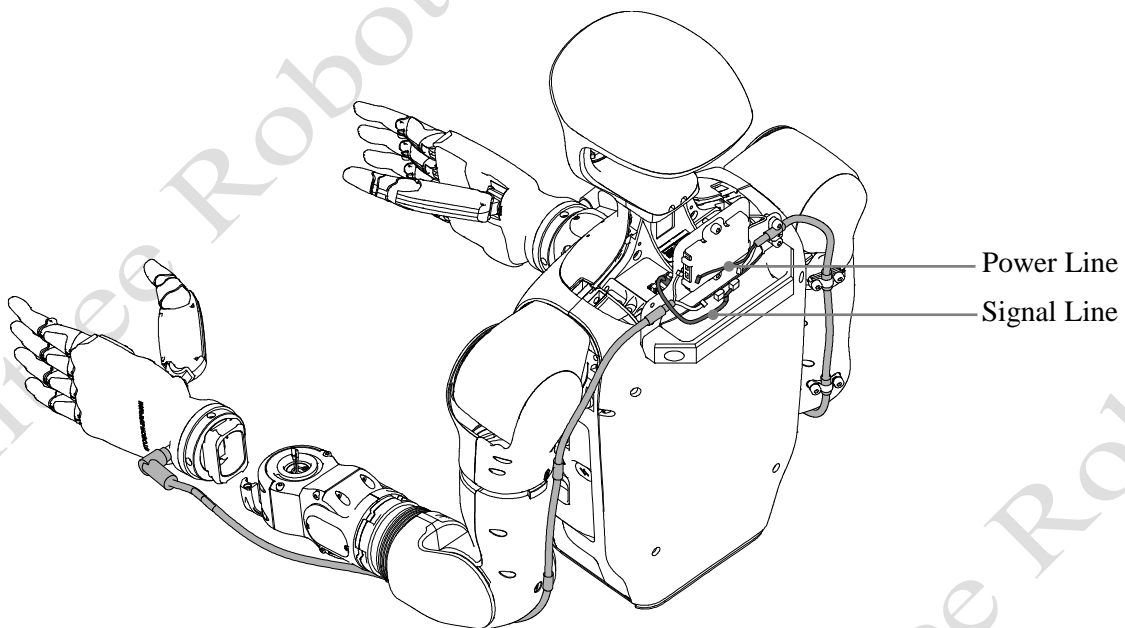

Installation Instructions

Step1: Install the Fixed Base, Signal Cable Circuit Board, and Fixed Cover

Remove two M6 screws, take out the handle, place the fixed base, reinstall the handle, and tighten the two M6 screws. Place the signal cable circuit board, install the fixed cover, and tighten two M4 screws.

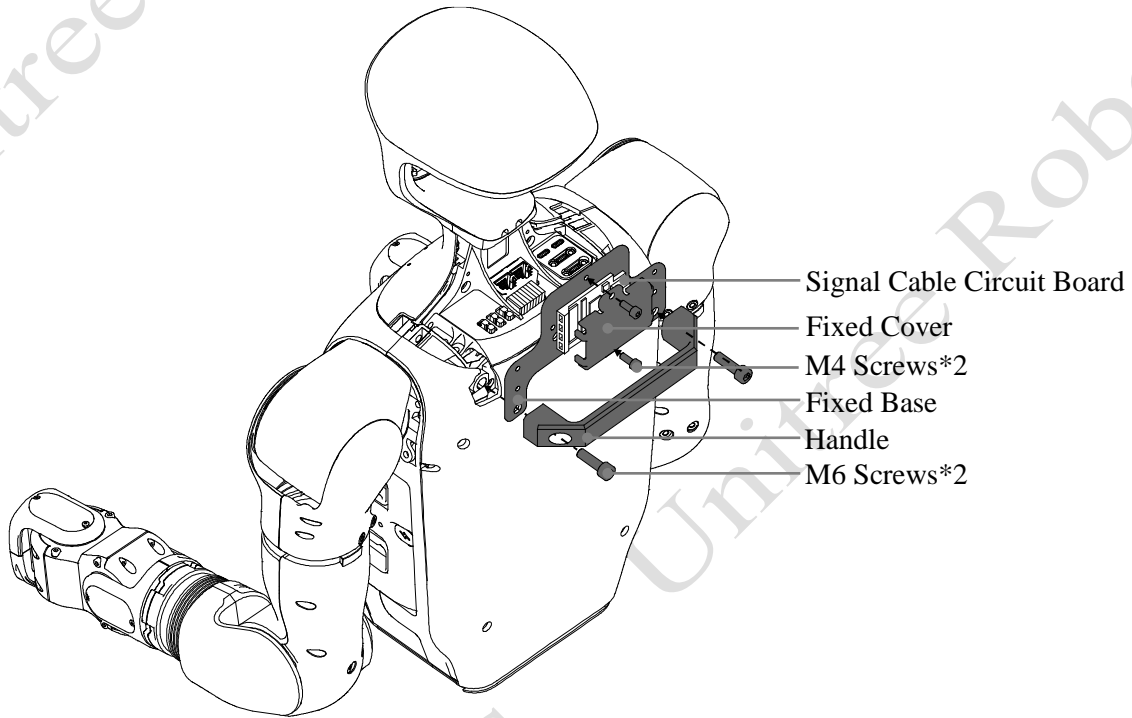

Step2: Install the INSPIRE Dexterous Hand

Before installing the hand, distinguish between left and right hands (method as shown).

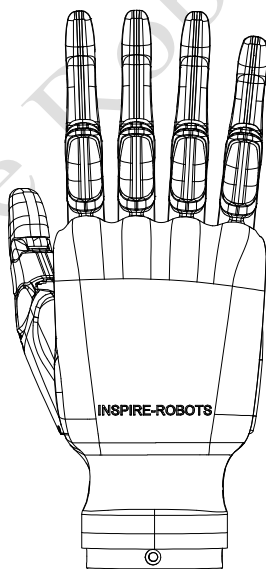

Right Hand

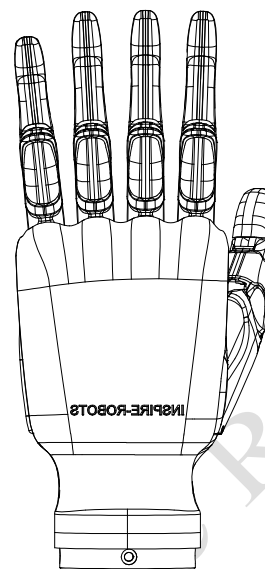

Left Hand

Place the dexterous hand, install the clamp (mind the cables), and tighten two M3 screws.

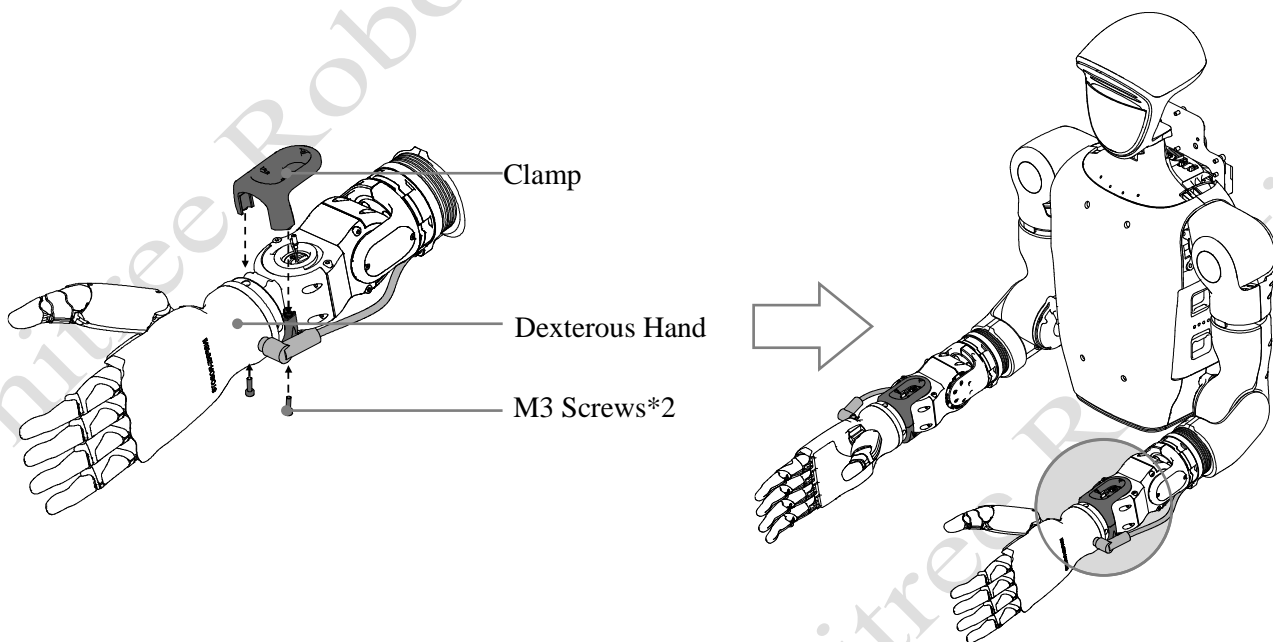

Step3: Install the cover plate

Place the cover plate, protect the cables, and tighten two M2 screws, as shown below.

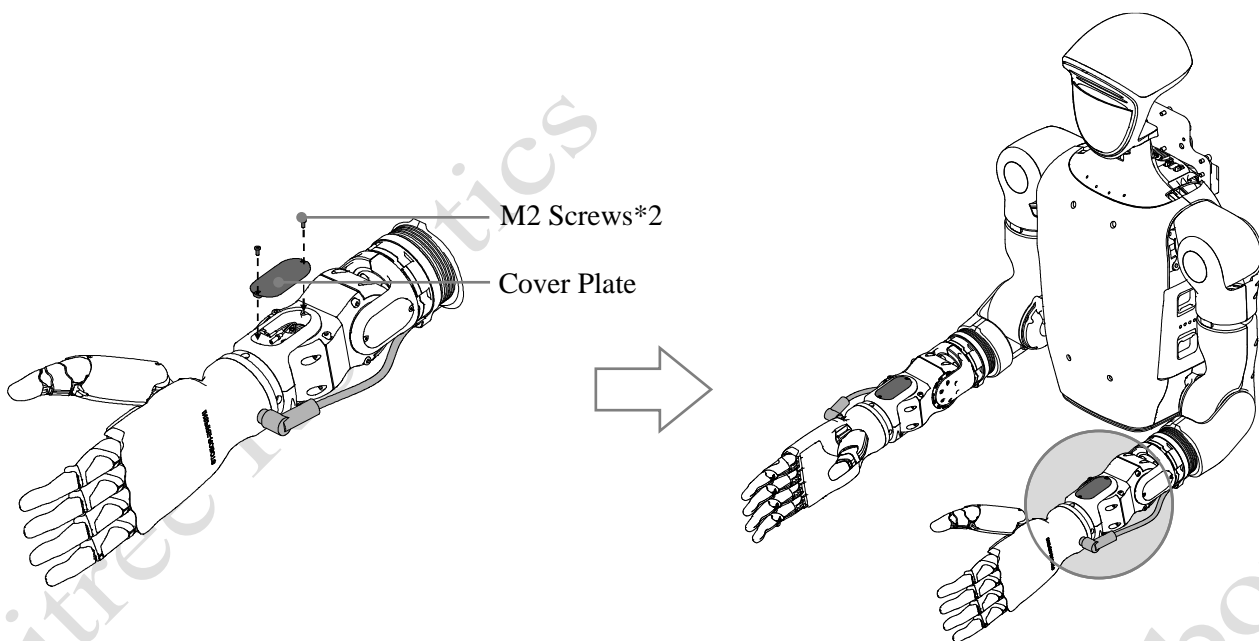

Step4: Install Cable Clamps

Place Cable Clamp 1 and tighten one M4 screw. Place Cable Clamp 2 and tighten two M4 screws. Place Cable Clamp 3 and tighten two M4 screws. Place Cable Clamp 4 and tighten two M4 screws, as shown below.

Note: There are four bolded sections on the cable. These correspond to Cable Clamps 1-4. Ensure the bolded sections are securely clamped to fix the cables properly!

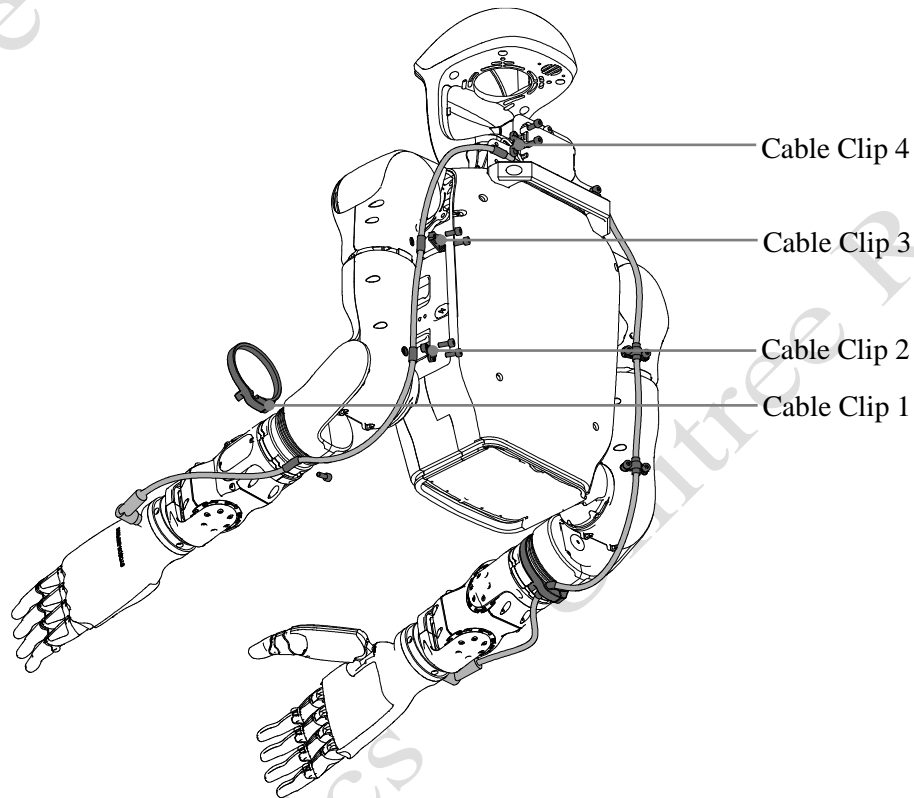

Step5: Connect the Connector

Plug in the connector firmly, as shown below.

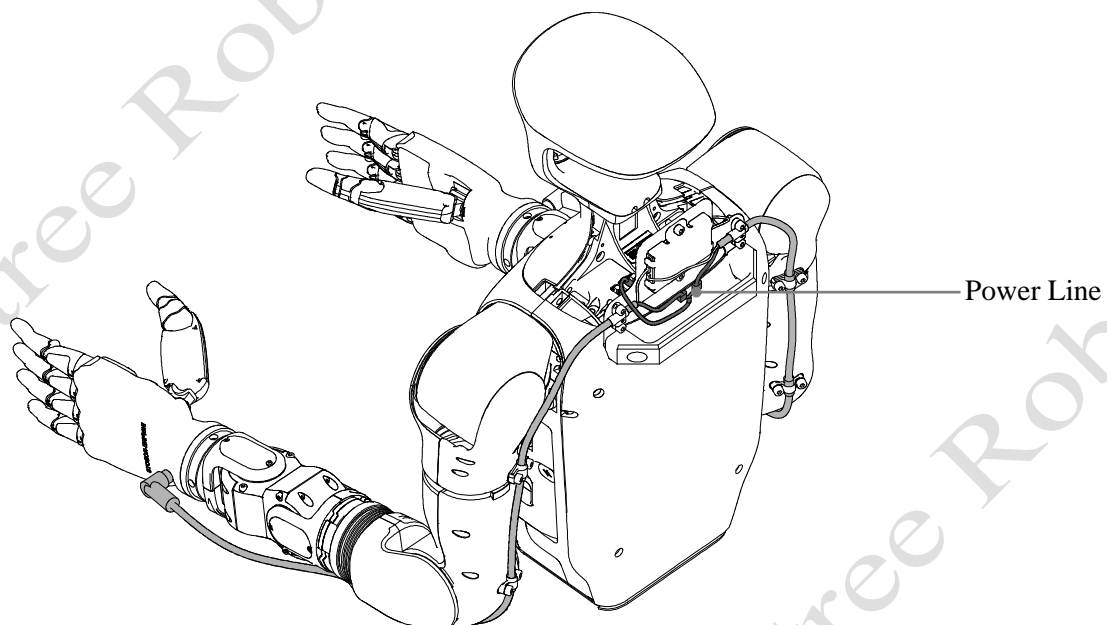

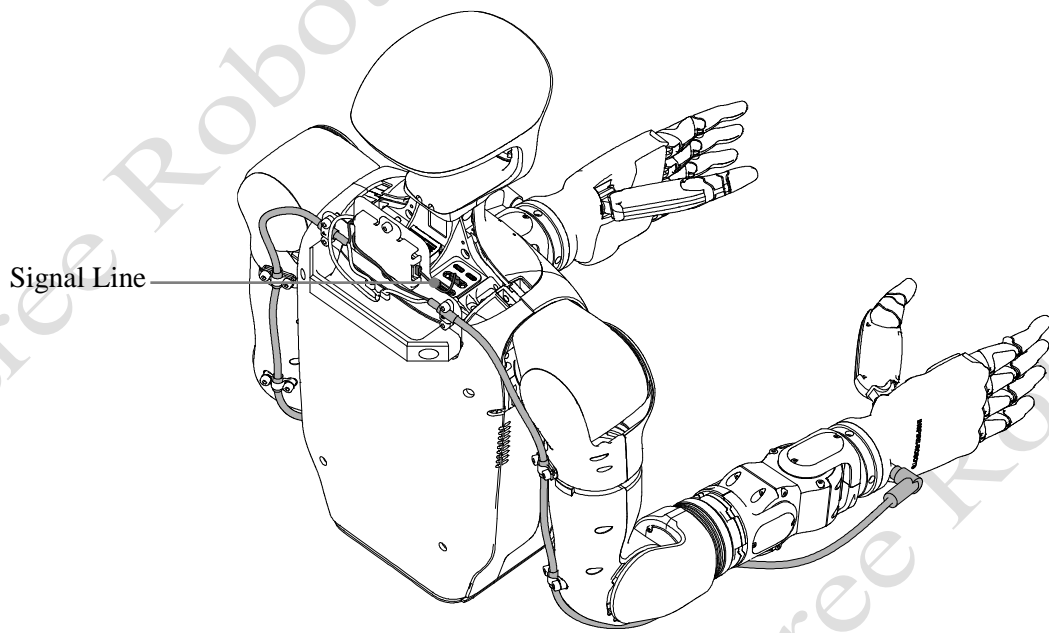

Step6: Complete the installation

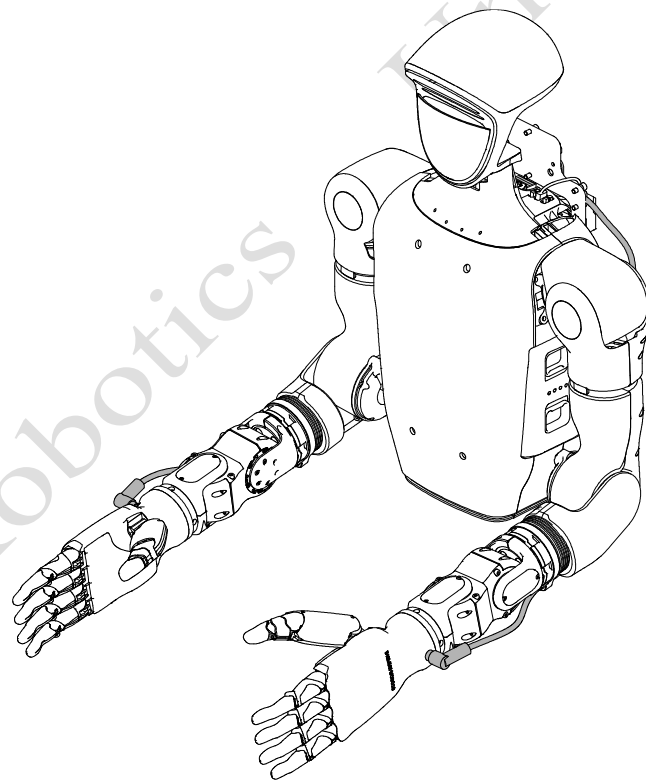

● **Attention!!!** When installing the three-fingered dexterous hand, please do not press the cable to avoid damaging the cable and causing poor contact!

● **Attention!!! After installing the dexterous hand, avoid movements such as squatting and lying down to prevent damage!!!**