

G1- Flagship Version A&B Terminal Three-Fingered Dexterous Hand Dex3-1

Disassembly and Assembly Guide Manual V1.1

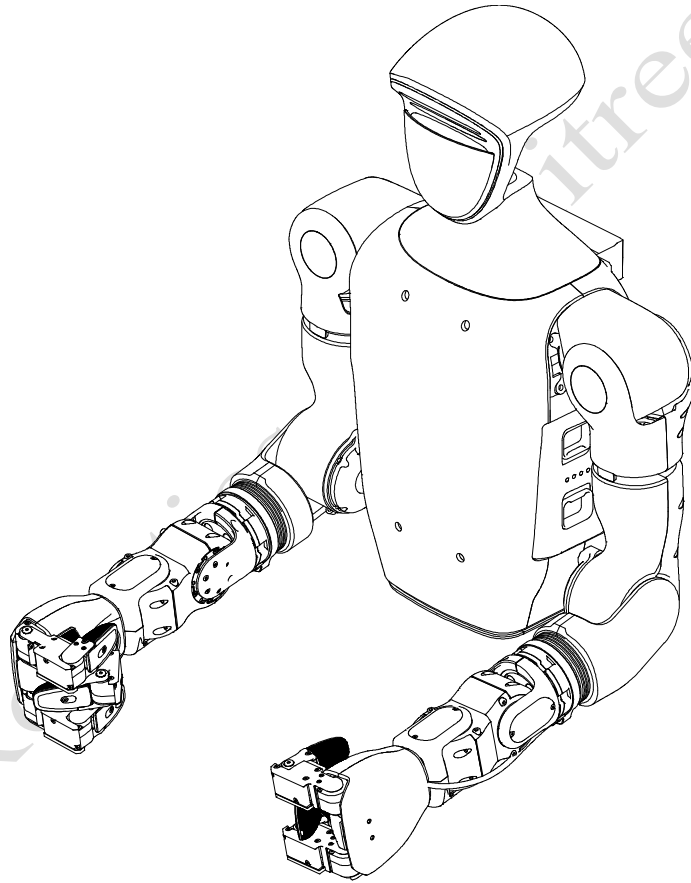

Unitree

After installing the dexterous hand, avoid movements such as squatting and lying down to prevent damage.

This product is a civilian robot. We kindly request that all users refrain from making any dangerous modifications or using the robot in a hazardous manner.

Please visit Unitree Robotics Website for more related terms and policies, and comply with local laws and regulations.

Catalogue

Disassembly Instructions	2
Step1: Disconnect the power connector of the hand	2
Step2: Remove the three-fingered dexterous hand Dex3-1	2
Step3: Remove the cable clips.....	3
Step4: Disconnect the back signal connector	3
Installation Instructions	4
Step1: Place the three-fingered dexterous hand Dex3-1	4
Step2: Connect the power connector of the hand	5
Step3: Install the cable clips	5
Step4: Connect the back signal connector	6
Step5: Install the back cover.....	6
Step6: Complete the installation	7

Disassembly Instructions

Step1: Disconnect the power connector of the hand

Remove the two M2 screws on the hand, take out the cover plate, and unplug the power connector of the hand, as shown in the following figure.

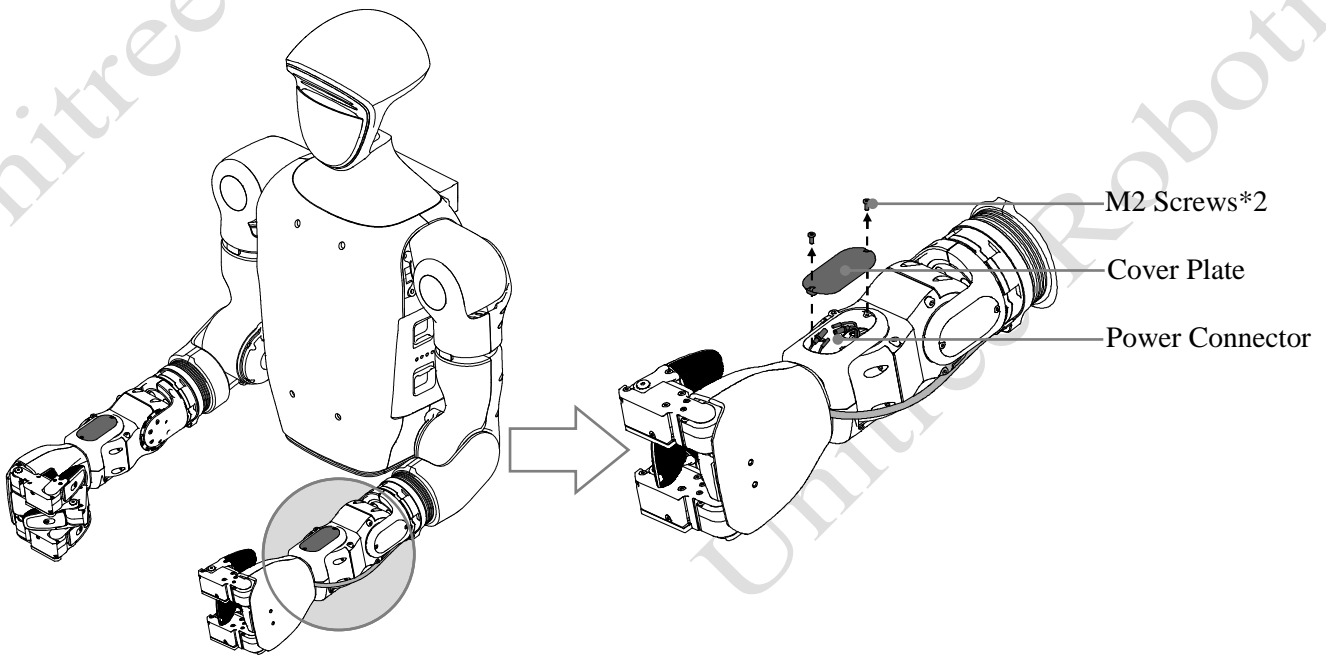

Step2: Remove the three-fingered dexterous hand Dex3-1

Remove the two M3 screws, take out the hoop (note the cable), and then take out the three-fingered dexterous hand Dex3-1, as shown in the following figure.

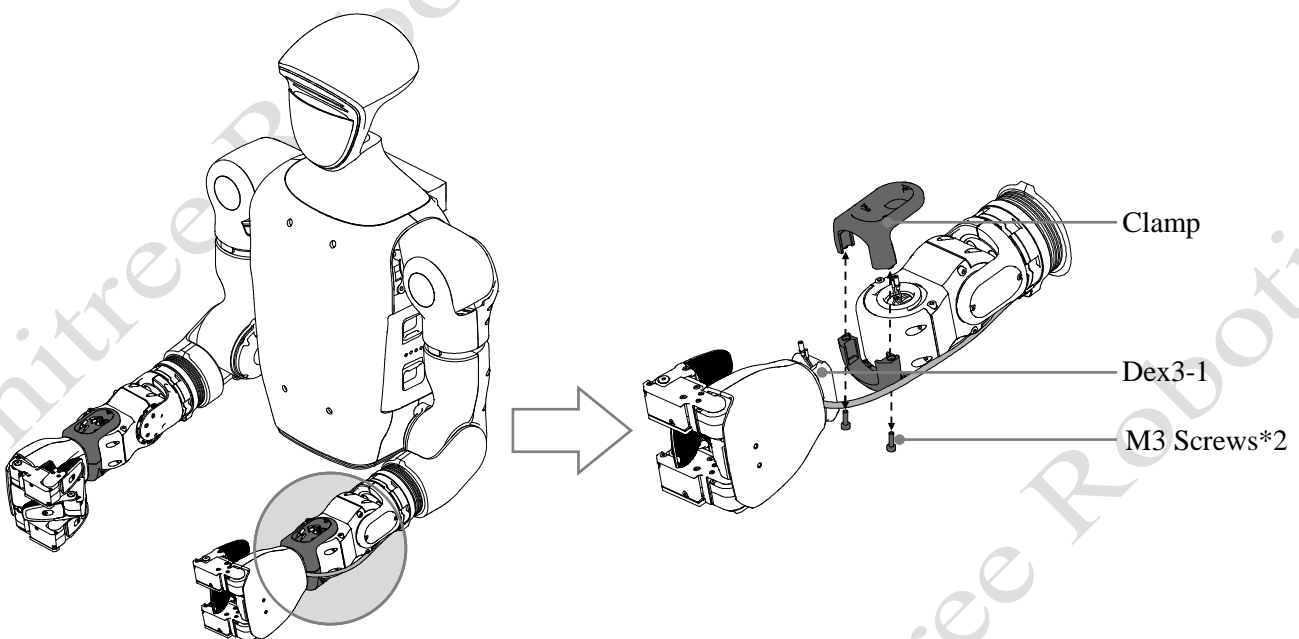

Step3: Remove the cable clips

Remove one M4 screw and take out Cable Clip One. Remove two M4 screws and take out Cable Clip Two. Remove two M4 screws and take out Cable Clip Three. Remove two M6 screws, take out the handle, and then take out the rear exterior part (it is of snap type or Velcro type, please operate carefully). Remove two M3 screws and take out Cable Clip Four, as shown in the following diagram.

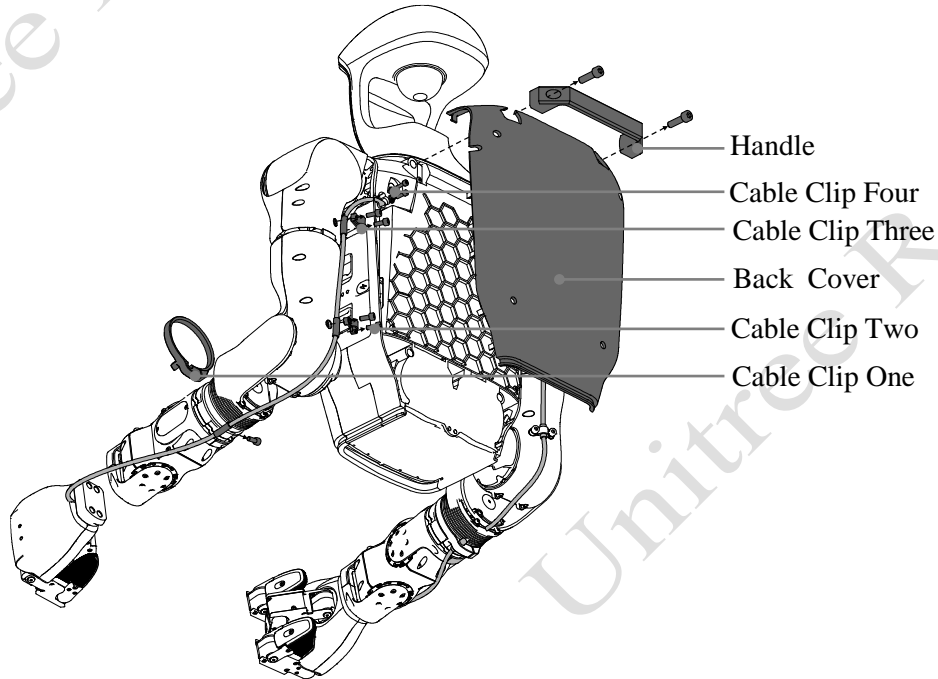

Step4: Disconnect the back signal connector

Remove the four M3 screws, take out the protective cover, and unplug the back signal connector, as shown in the following figure.

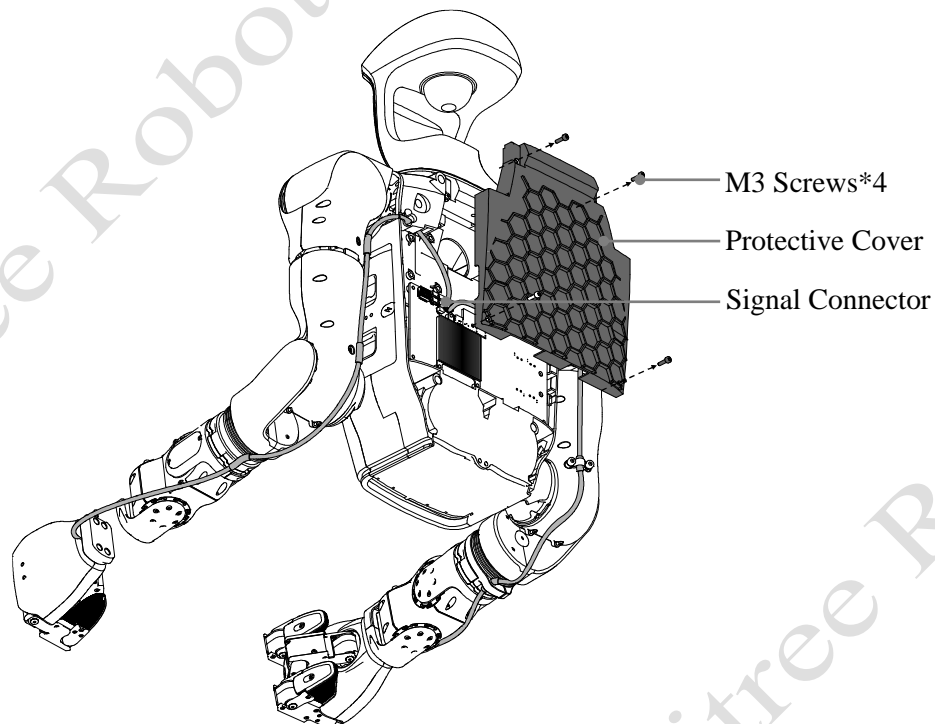

Installation Instructions

Step1: Place the three-fingered dexterous hand Dex3-1

Place the three-fingered dexterous hand Dex3-1 (note to distinguish between the left and right hands and the placement direction), place the hoop (note the cable), and tighten the two M3 screws, as shown in the following figure.

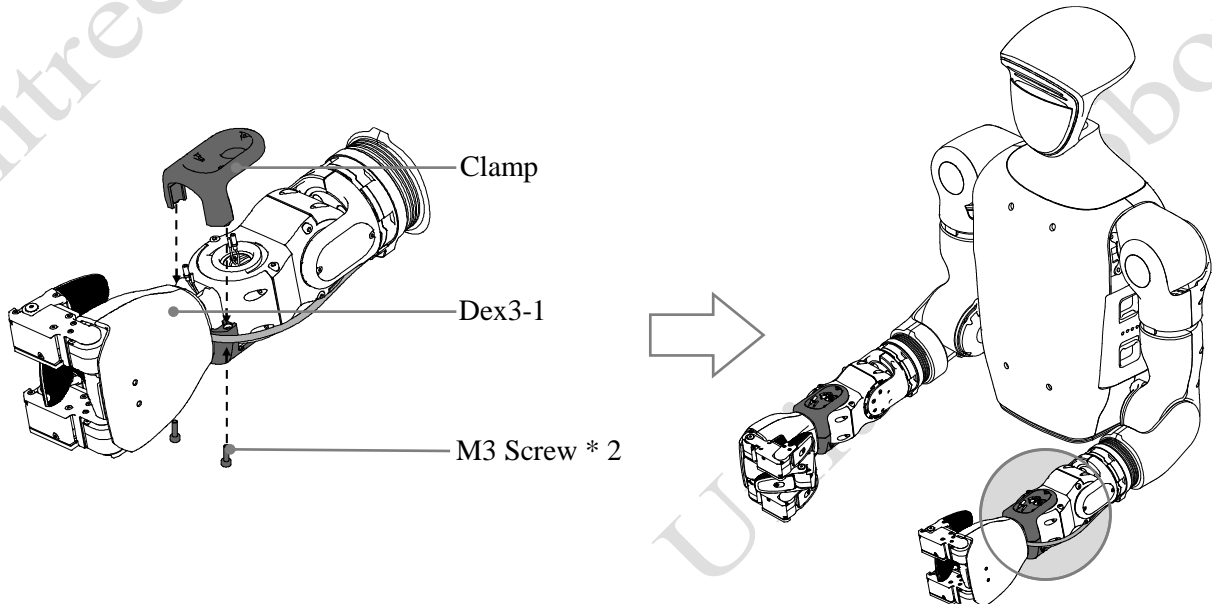

Distinguishing between the left and right dexterous hands: Place the Dex3 - 1 dexterous hand in the posture as shown in the figure.

Method 1: Distinguish by the "L" and "R" at the base of the thumb. The one engraved with "L" is the left - hand dexterous hand, and the one engraved with "R" is the right - hand dexterous hand.

Method 2: Distinguish according to the direction of the power cable. The dexterous hand with the power cable facing left is the left - hand one, and the dexterous hand with the power cable facing right is the right - hand one.

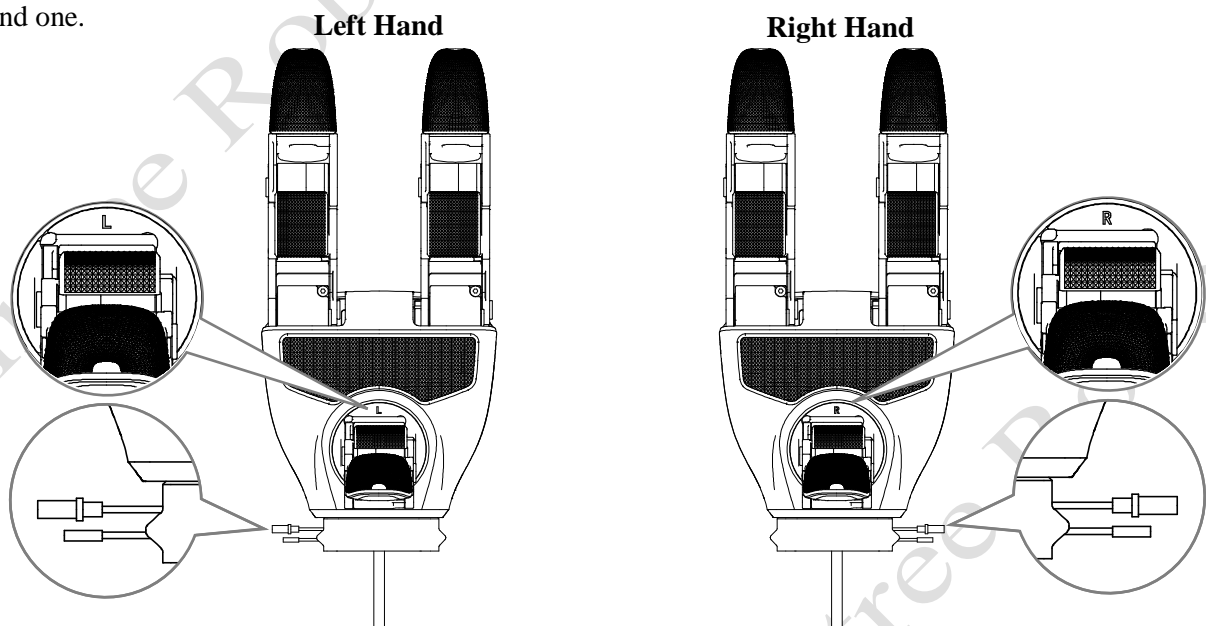

Step2: Connect the power connector of the hand

Insert the power connector of the hand tightly, place the cover plate, and tighten the two M2 screws, as shown in the following figure.

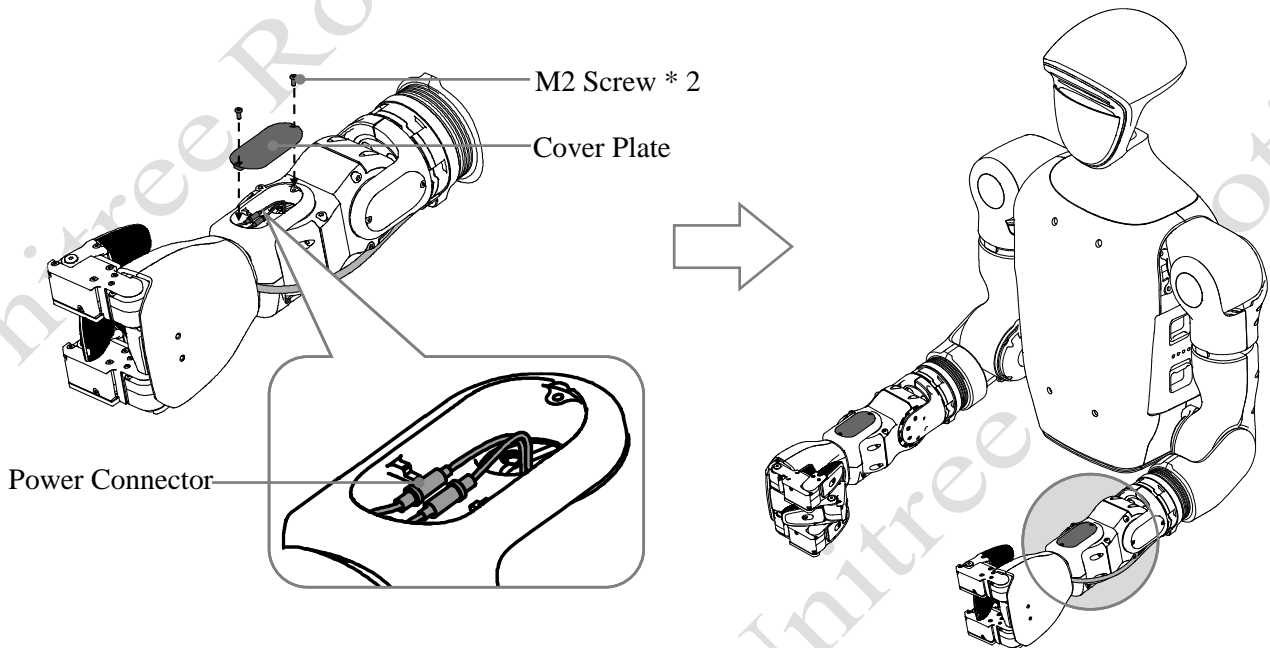

Step3: Install the cable clips

Insert Cable Clip One and tighten one M4 screw. Insert Cable Clip Two and tighten two M4 screws. Insert Cable Clip Three and tighten two M4 screws. Insert Cable Clip Four and tighten two M3 screws, as shown in the following diagram. **Note:** There are a total of four thickened positions on the cable. These four positions correspond to Cable Clip One, Two, Three, and Four respectively. Only by clamping the thickened positions of the cable in the cable clips can the cable be fixed firmly!

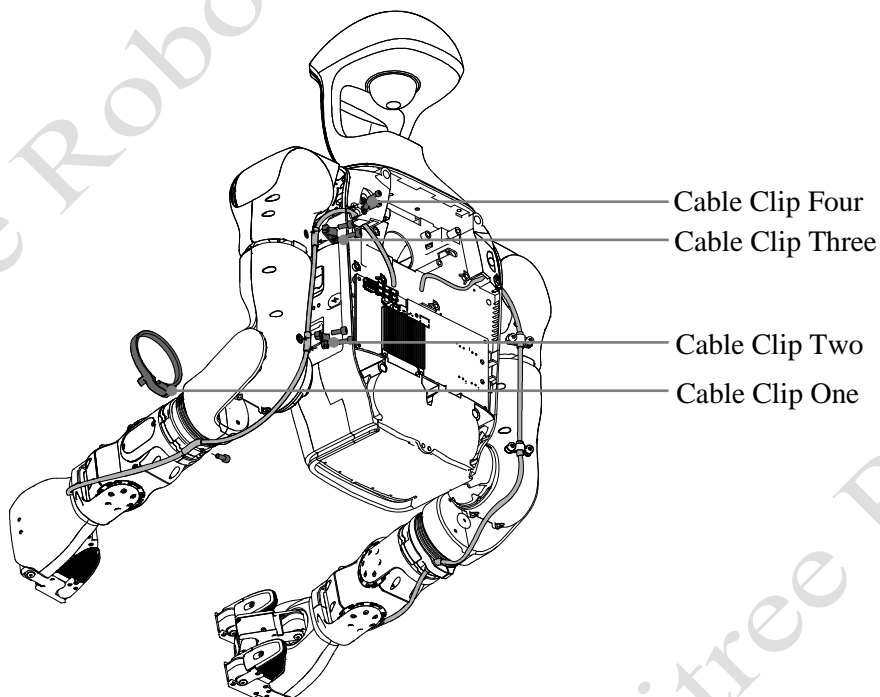

Step4: Connect the back signal connector

Insert the back signal connector tightly. The internal wiring of the fuselage needs to avoid the heat sink fins, the air inlet of the fan, and the support bars!!!

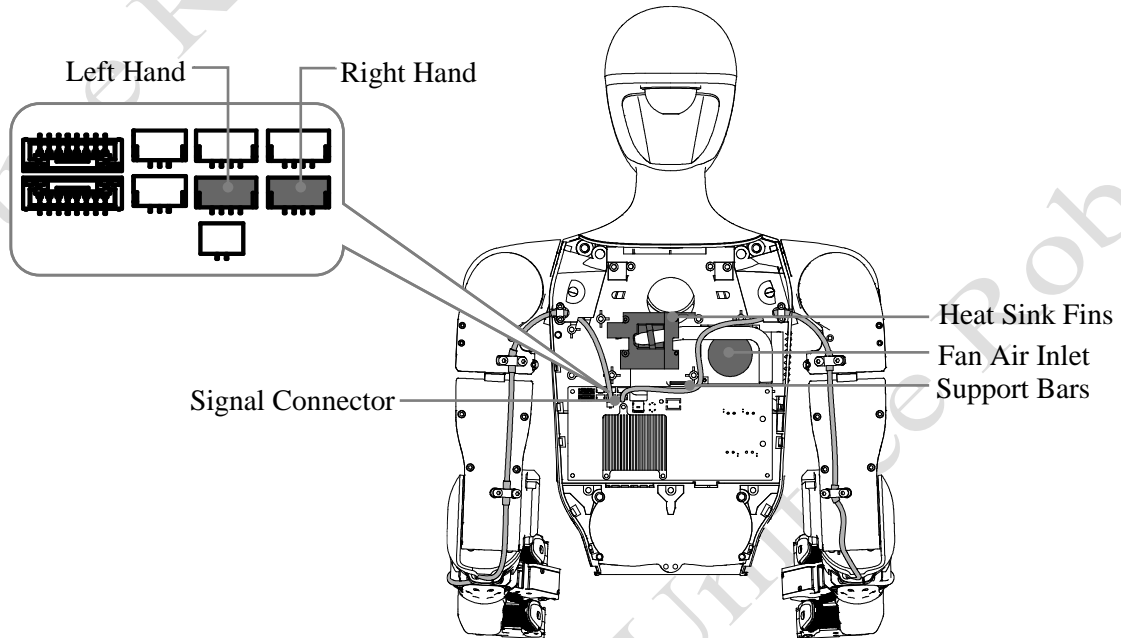

Step5: Install the back cover

Place the protective cover and tighten the four M3 screws. Place the back shell (it is snap-on or with Velcro, please operate carefully).

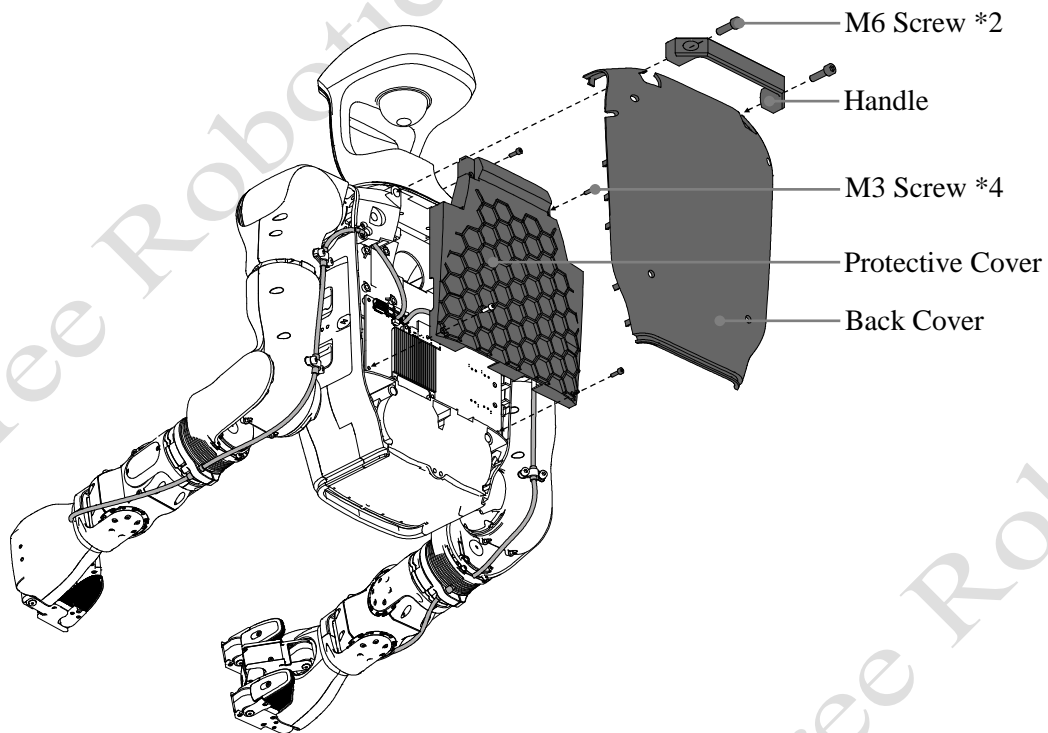

Step6: Complete the installation

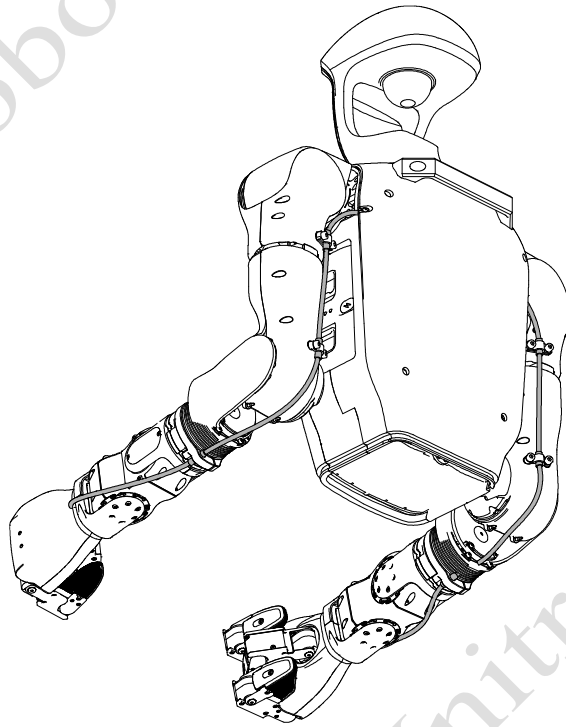

- Attention!!! When installing the three-fingered dexterous hand, please do not press the cable to avoid damaging the cable and causing poor contact!
- **Attention!!! After installing the dexterous hand, avoid movements such as squatting and lying down to prevent damage!!!**